



# LESSON

# 14

## Solving Problems with Right Triangles

Trigonometry can be applied to solve various geometric problems.

**EXAMPLE A** Find the area of a regular pentagon with sides 6 feet long and angles of  $108^\circ$ .

1

Draw the pentagon and divide it into five congruent triangles.

The result is five isosceles triangles, each with two base angles measuring  $54^\circ$ .

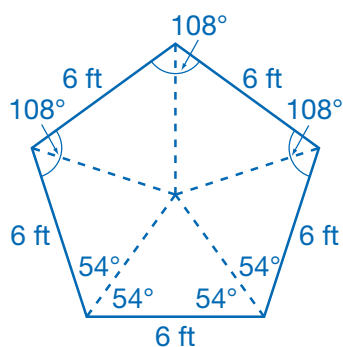

2

Draw an **apothem** of the pentagon.

The apothem connects the center to the midpoint of a side. It is also the altitude and median of one of the isosceles triangles. So, it bisects the base (the side of the pentagon) into two congruent 3-ft segments.

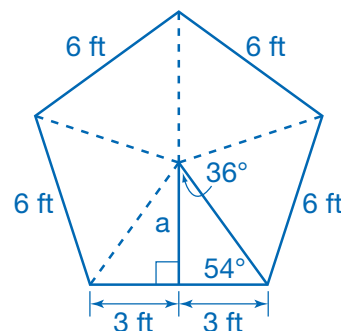

3

Find the length of the apothem.

$$\begin{aligned}\tan 54^\circ &= \frac{a}{3} \\ 3(\tan 54^\circ) &= a \\ 4.13 &\approx a\end{aligned}$$

4

Find the area of the pentagon.

Find the area of the triangle.

$$A_{\text{triangle}} = \frac{1}{2}ba \approx \frac{1}{2} \cdot 6 \cdot 4.13 = 12.39 \text{ ft}^2$$

The pentagon is made up of five such triangles, so its area is  $5A_{\text{triangle}}$

$$\blacktriangleright A_{\text{pentagon}} \approx 5(12.39 \text{ ft}^2) = 61.95 \text{ ft}^2$$

### DISCUSS

Leo says that if the pentagon had 8-foot sides, its area would be  $A \approx 5 \cdot \frac{1}{2}(8)(4.13)$ . What error did Leo make?

**EXAMPLE B** Derive a formula for the area of  $\triangle ABC$  using trigonometry.

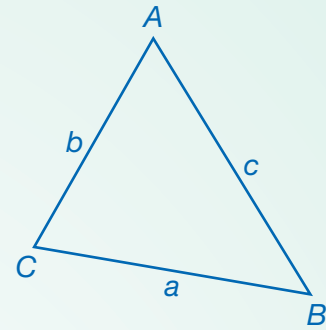

**1** Draw an altitude from  $\angle A$ .

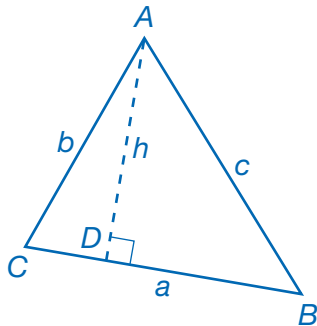

Let  $D$  be the point where the altitude meets side  $\overline{BC}$ , and let  $AD = h$ .

**2** Find an expression for  $h$ .

Using right triangle  $ADC$ , find the sine ratio for angle  $C$ .

$$\sin C = \frac{\text{opposite}}{\text{hypotenuse}}$$

$$\sin C = \frac{h}{b}$$

Find the height,  $h$ , of the triangle by multiplying both sides of the trigonometric equation by  $b$ .

$$\sin C = \frac{h}{b}$$

$$b \sin C = h$$

**3** Find the area of  $\triangle ABC$ .

Substitute  $a$  for the base and  $h$  for the height.

$$\text{Area} = \frac{1}{2} \text{base} \times \text{height}$$

$$\text{Area} = \frac{1}{2} ah$$

Substitute  $b \sin C$  for  $h$ .

$$\text{Area} = \frac{1}{2} ab \sin C$$

**TRY**

Find the area of the triangle below.

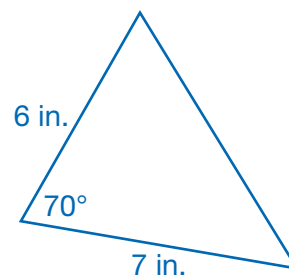

Using an inverse trigonometric function, such as  $\sin^{-1}$ ,  $\cos^{-1}$ , or  $\tan^{-1}$ , allows you to determine an unknown angle measure given sides of a right triangle.

**EXAMPLE C** Amy needs to place a 6-meter ladder against a house so that it reaches a height of 5.5 meters. At what angle will she need to place the ladder? Find your answer to the nearest degree.

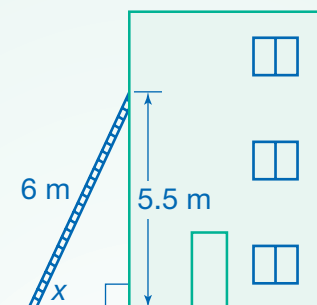

1

Write an equation using  $x$ .

The measure of the angle,  $x$ , is unknown.

The side opposite the unknown angle is 5.5 meters, and the hypotenuse is 6 meters. Since the opposite leg and hypotenuse are known, use the sine function.

$$\sin x = \frac{5.5}{6}$$

2

Use an inverse trigonometric function to solve for  $x$ .

The inverse of the sine function is the inverse sine function,  $\sin^{-1}x$ . Apply this function to both sides of the equation.

$$\sin^{-1}(\sin x) = \sin^{-1}\left(\frac{5.5}{6}\right)$$

$$x = \sin^{-1}\left(\frac{5.5}{6}\right)$$

The inverse function cancels out the sine function on the left side of the equation. To calculate the right side, press

**2nd** **SIN** on your calculator and enter  $5.5 \div 6$ . Then press **ENTER**

$$x \approx 66.44$$

► Amy should place the ladder at about a  $66^\circ$  angle.

CHECK

Use the sine function on your calculator to check the answer.

An **angle of elevation** is the angle formed by a horizontal line and the line of sight to an object above that horizontal line. An **angle of depression** is the angle formed by a horizontal line and the line of sight to an object below that horizontal line.

**EXAMPLE D** An airplane is approaching a landing strip at a  $3^\circ$  angle of depression, starting from a height of 3,000 feet. To the nearest hundredth of a mile, what is  $d$ , the horizontal distance of the airplane from the airport?

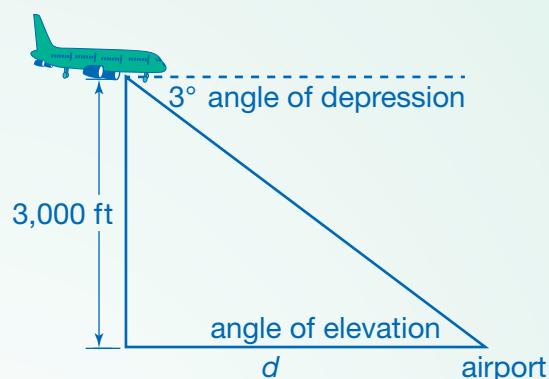

**1** Write an equation using  $d$

The dashed horizontal line, from which the angle of depression is measured, is parallel to the ground. This means that the angle of depression and the angle of elevation are alternate interior angles, so they are congruent. The angle of elevation is also  $3^\circ$ .

The altitude of the plane is the leg opposite the angle of elevation and the distance  $d$  is the adjacent leg. Use the tangent function.

$$\tan 3^\circ = \frac{3,000}{d}$$

**2** Solve for  $d$ .

$$\begin{aligned} \tan 3^\circ &= \frac{3,000}{d} \\ d(\tan 3^\circ) &= 3,000 \\ d &= \frac{3,000}{\tan 3^\circ} \\ d &\approx 57,243.41 \text{ ft} \end{aligned}$$

**3** Convert from feet to miles.

$$57,243.41 \text{ ft} \cdot \frac{1 \text{ mi}}{5,280 \text{ ft}} \approx 10.84 \text{ mi}$$

► The airplane is starting its descent when it is approximately 10.84 miles from the airport.

**MODEL**

If a plane began descending from an altitude of 10,000 feet at a vertical distance of 114,300 feet from the airport, what would be its angle of descent?

**EXAMPLE E** A wheelchair accessible ramp must have an angle of elevation of no more than  $9.5^\circ$ . Determine the length of ramp needed to reach a doorway that is 4.5 feet off the ground. How far from the door will the ramp start?

1

Draw a diagram.

The ramp will form a right triangle with the ground and the entrance to the door. The ramp will be the hypotenuse. Label the angle of elevation  $9.5^\circ$ .

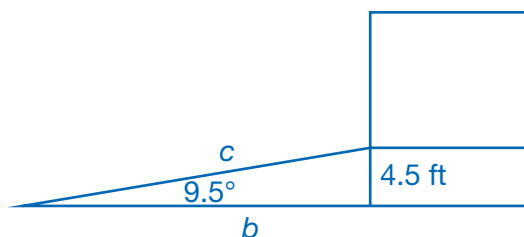

2

Find the length of the ramp.

The ramp forms the hypotenuse of a right triangle with one acute angle measuring  $9.5^\circ$  and the leg opposite it measuring 4.5 feet. Use the sine function to relate these known values to the length of the ramp.

$$\sin 9.5^\circ = \frac{4.5}{c}$$

Solve for  $c$ .

$$c(\sin 9.5^\circ) = 4.5$$

$$c = \frac{4.5}{\sin 9.5^\circ}$$

$$c \approx 27.26$$

► The ramp must be at least 27.26 feet long.

3

Find the distance from the door to the start of the ramp.

The distance along the ground is the other leg of the right triangle. Note that this is the leg adjacent to the  $9.5^\circ$  angle.

$$\tan 9.5^\circ = \frac{4.5}{b}$$

$$b = \frac{4.5}{\tan 9.5^\circ}$$

$$b \approx 26.89$$

► The ramp must start at least 26.89 feet from the door.

CHECK

Use the Pythagorean Theorem to check these answers.



# Problem Solving

## READ

Juan is a firefighter. From the ground, he sees a cat in a tree. Juan is 90 feet from the tree, and his eye level is 5 feet above the ground. The angle of elevation from his eyes to the cat is  $25^\circ$ . What is the elevation of the cat above the ground to the nearest tenth of a foot?

## PLAN

Draw a diagram to represent the problem. Account for the fact that the firefighter's eye level is 5 feet above the ground.

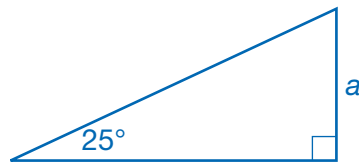

The 90-ft side is adjacent to the  $25^\circ$  angle. The side labeled  $a$  is \_\_\_\_\_ the  $25^\circ$  angle.

So, use the \_\_\_\_\_ function to find the value of  $a$ . Then you can add 5 feet to find the total elevation of the cat above the ground.

## SOLVE

$$\tan 25^\circ = \frac{a}{\square}$$

$$(\text{_____}) \tan 25^\circ = a$$

$$\text{_____} \approx a$$

Juan's eye level is \_\_\_\_\_ feet above the ground. So, add \_\_\_\_\_ feet to the value of  $a$  to find the cat's total elevation.

$$\text{_____} + \text{_____} = \text{_____} \text{ feet}$$

## CHECK

Use the inverse of tangent,  $\tan^{-1}$ , to check your answer. Remember to use the value for  $a$ , not the elevation of the cat.

On your calculator, press **2nd** **TAN**. Enter \_\_\_\_\_  $\div$  90 and press **ENTER**.

Is the result approximately equal to the original angle? \_\_\_\_\_

► The cat is about \_\_\_\_\_ feet above the ground.

# Practice

Choose the best answer. You may use your calculator.

1. A jet is capable of a steady  $15^\circ$  climb. What is  $a$ , the approximate altitude of the jet, in meters, after it moves 800 meters through the air?

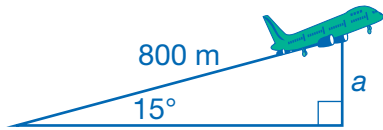

- A. 207 m                      C. 772 m  
B. 309 m                      D. 828 m

2. At a certain time of day, Sean, who is 6 feet tall, casts an 8-foot shadow. What is the approximate angle of elevation of the sun when this shadow is cast?

- A.  $37^\circ$                       C.  $53^\circ$   
B.  $49^\circ$                       D.  $68^\circ$



The figure and its shadow form a right triangle. The location of the sun determines the angle.

3. What is the area of  $\triangle ABC$ , to the nearest tenth of a square foot?

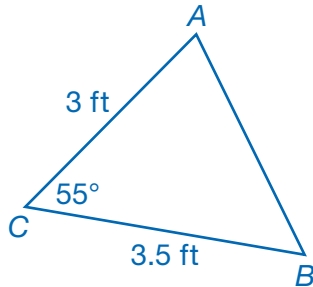

- A.  $3.9 \text{ ft}^2$                       C.  $4.6 \text{ ft}^2$   
B.  $4.3 \text{ ft}^2$                       D.  $4.9 \text{ ft}^2$

4. When the sun's angle of elevation is  $56^\circ$ , a tree casts a shadow that is 60 feet long. What is the height of the tree to the nearest foot?

- A. 40 ft  
B. 50 ft  
C. 89 ft  
D. 116 ft

Use the diagram of a 16-foot ladder leaning against a building for questions 5 and 6.

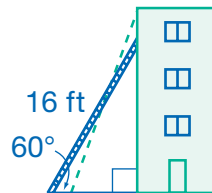

5. If the ladder makes an angle of  $60^\circ$  with the ground, how high does it reach? Give an exact answer and give an answer to the nearest inch.

\_\_\_\_\_

6. Suppose the ladder is adjusted to be at an angle of  $70^\circ$  with the ground. Approximately how many inches higher will it reach?

\_\_\_\_\_

**REMEMBER** The sides of a  $30^\circ$ - $60^\circ$ - $90^\circ$  triangle are in the ratio  $x$ ;  $x\sqrt{3}$ ;  $2x$ .

**Solve.**

7. The bed of a mover's truck is 4 feet above the ground. The owner of the moving company needs to build a ramp with an angle of elevation of no more than  $20^\circ$ . How long should the ramp be?

---

8. A lighthouse keeper spots a boat out at sea. The angle of depression from the keeper to the boat is  $4^\circ$ . The keeper's viewing level from the top of the lighthouse is 102 feet above sea level. What is  $d$ , the distance from the boat to the lighthouse, to the nearest foot?

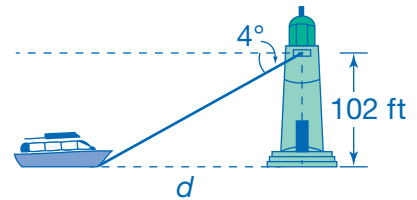

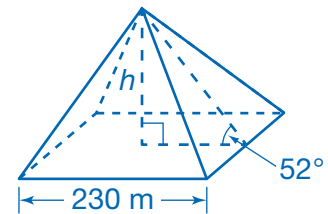

---

9. The Great Pyramid of Giza in Egypt is a right square pyramid with base lengths of approximately 230 meters. The faces of the pyramid are inclined at  $52^\circ$  angles. What is the approximate height of the Great Pyramid to the nearest tenth of a meter?

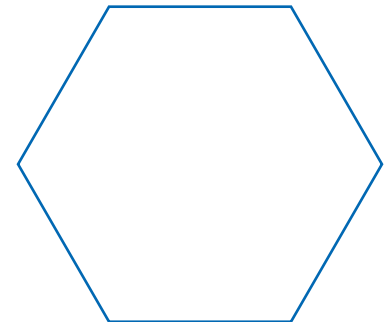

---

10. **APPLY** A tent for a party has a base shaped like a regular hexagon with each side measuring 4 yards and each angle measuring  $120^\circ$ . There should be 10 square feet of space for each guest at the party. How many people can fit in the tent? Explain.



---



---



---

11. **MODEL** Forest rangers at two lookout towers each see the same forest fire. Tower A is 20 km west of Tower B. The fire is directly southeast of Tower A and directly southwest of Tower B. Approximately how far is the fire from each tower? Draw a model and use it to help explain your work.

---