

Circles and Line Segments

Chords, Radii, and Diameters

UNDERSTAND A **circle** is the collection of points that are equidistant from a given point, which is called the center. The distance from the center to a point on the circle is the length of a **radius** of the circle. So, every radius that can be drawn in the circle has the same length. A circle is usually named by its center, so a circle whose center is point Q is named circle Q , or $\odot Q$.

A **chord** is a line segment that has both endpoints on a circle. Two chords within the same circle can have different lengths. A **diameter** is a chord that passes through the center of a circle. Diameters are the longest possible chords in a circle, so all of a circle's diameters are the same length. The length of the diameter of a circle is twice the length of its radius.

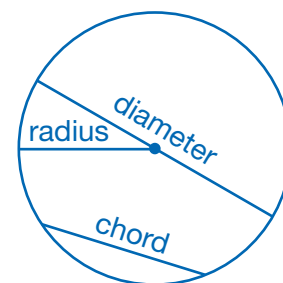

UNDERSTAND Relationships among these line segments can help you determine their lengths.

If two chords intersect and divide each other into segments, the product of the segments of one chord equals the product of the segments of the other chord.

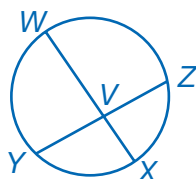

$$WV \cdot VX = YV \cdot VZ$$

If a radius or a diameter intersects a chord and is perpendicular to the chord, it bisects the chord.

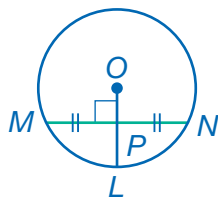

In circle O , $\overline{OL} \perp \overline{MN}$ and $MP = PN$.

The converse is also true. If a radius or diameter bisects a chord, then it is perpendicular to the chord.

Connect

Chords \overline{FG} and \overline{HJ} intersect at point Z . $HZ = 6$, $FZ = 3$, and $ZG = 8$. Find the length of \overline{ZJ} .

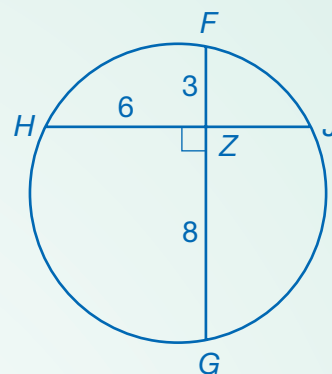

Set up an equation and solve for ZJ .

$$HZ \cdot ZJ = FZ \cdot ZG$$

$$6 \cdot ZJ = 3 \cdot 8$$

$$6ZJ = 24$$

► $ZJ = 4$

Diameter \overline{PQ} intersects chord \overline{RS} at point T . The segments are perpendicular to each other. $PT = 9$ and $TQ = 4$. Find the length of \overline{RT} .

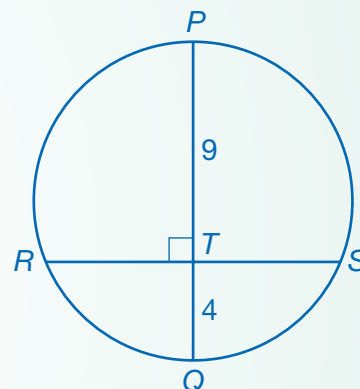

1

Compare \overline{RT} and \overline{TS} .

Since \overline{PQ} is a diameter perpendicular to \overline{RS} , it must bisect \overline{RS} . Therefore, $RT = TS$.

2

Set up an equation and solve for RT .

A diameter is a special type of chord, so use the equation for parts of a chord.

$$RT \cdot TS = PT \cdot TQ$$

$$RT \cdot TS = 9 \cdot 4$$

Because $RT = TS$, substitute RT for TS .

$$RT \cdot RT = 9 \cdot 4$$

$$RT^2 = 36$$

► $RT = 6$

DISCUSS

If two chords intersect such that each chord is the perpendicular bisector of the other chord, what is true about the chords? Where do they intersect?

Secant Lines and Tangent Lines

UNDERSTAND A **secant line** is a line in the plane that intersects a circle at two points. A secant could be formed by extending the ends of a chord. A **tangent line** intersects a circle at exactly one point. That point is called the point of tangency. The radius drawn to a point of tangency is perpendicular to the tangent line through that point.

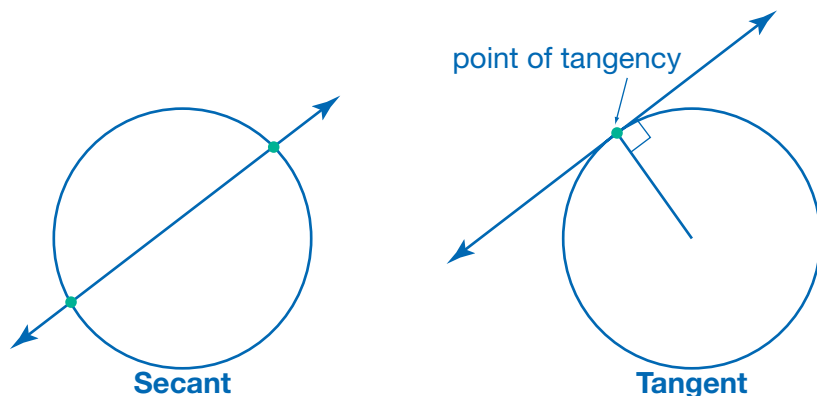

UNDERSTAND \overleftrightarrow{KL} and \overleftrightarrow{MN} are secant lines that intersect at point P . Segments such as KP and MP are called secant segments. The portion of a secant segment outside the circle, such as \overline{LP} or \overline{NP} , is called an external segment. If two secant lines intersect outside a circle, the product of the secant segment and external segment of one secant line is equal to the product of the secant segment and external segment of the other secant line.

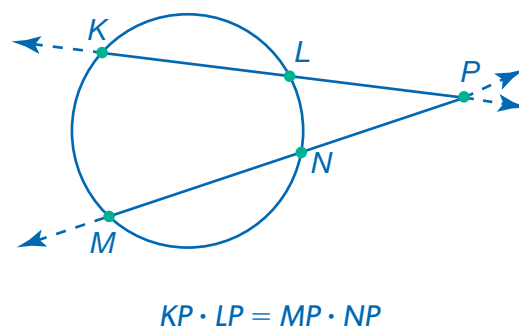

Imagine pulling secant \overleftrightarrow{MN} down. Points M and N , which are located where the line intersects the circle, would move down the circle and come closer together. If you pulled the line down far enough, M and N would become the same point. The line would now be tangent to the circle.

If we call this single point of tangency S , the diagram is now changed so that secant \overleftrightarrow{MN} is replaced by tangent \overleftrightarrow{SP} . Segment MP is replaced by segment SP , and segment NP is also replaced by segment SP . So, the product of KP and LP is equal to SP squared.

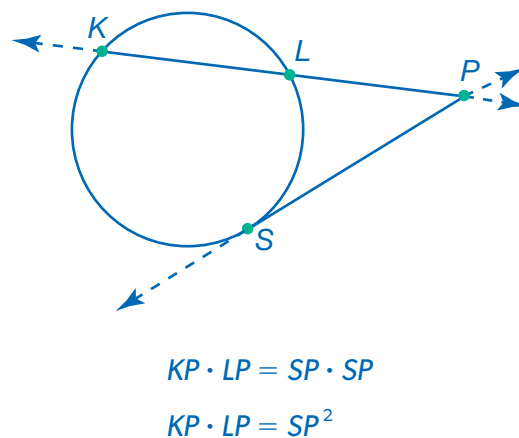

Connect

In the diagram, $AB = 2$, $BC = 15$, and $AD = 3$. What is the length of chord DE ?

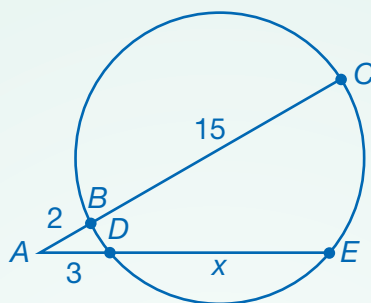

1

Identify the types of lines and line segments.

\overleftrightarrow{AC} intersects the circle at two points, B and C . So, it is a secant. \overline{AC} is its secant segment, and \overline{AB} is its external segment.

\overleftrightarrow{AE} also intersects the circle at two points, D and E . It is also a secant. \overline{AE} is its secant segment, and \overline{AD} is its external segment.

2

Find the lengths of the secant segments.

The length of secant segment \overline{AC} is the sum of the length of external segment \overline{AB} and internal segment \overline{BC} .

$$AC = AB + BC = 2 + 15 = 17$$

The length of secant segment \overline{AE} is the sum of the length of external segment \overline{AD} and internal segment \overline{DE} .

$$AE = AD + DE = 3 + x$$

3

Find the length of the internal segment.

The product of the secant segment and external segment must be the same for each secant line.

$$AC \cdot AB = AE \cdot AD$$

$$17 \cdot 2 = (3 + x) \cdot 3$$

$$34 = 9 + 3x$$

$$25 = 3x$$

$$8\frac{1}{3} = x$$

► Chord DE is $8\frac{1}{3}$ units long.

TRY

If tangent line \overleftrightarrow{AF} were drawn so that point F were on the circle above, what would be the length of \overline{AF} ?

EXAMPLE A Circles A and B have different radii, as shown. Show that these two circles are similar figures.

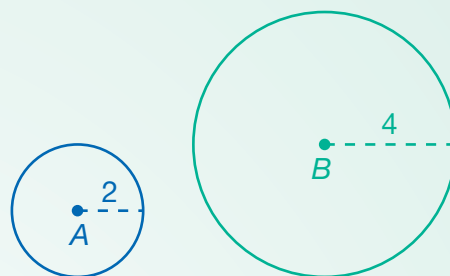

1

Select a transformation that will show similarity.

Dilations produce similar images.

So, if circle A can be dilated to form circle B , the two figures are similar.

The radius of circle B is 4, which is 2 times the radius of circle A . So, the dilation should have a scale factor of 2.

2

Transform circle A .

Translate circle A to the right so that it has the same center as circle B .

Then dilate circle A by a factor of 2 from its center.

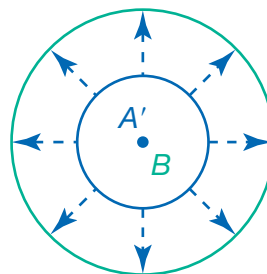

3

Compare the circles.

Circle B has a radius of 4 units.

Circle A has a radius of 2 units. Circle A' , its image after a translation and a dilation by a factor of 2, has distances twice that of circle A . So, circle A' has a radius of 4.

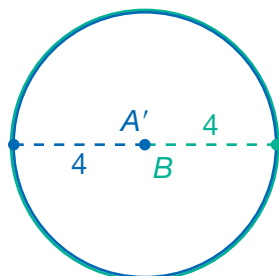

All points on circles A' and B are 4 units from the center, so the circles are congruent.

▶ Since a dilation of circle A produced an image congruent to circle B , circles A and B are similar.

DISCUSS

Are all circles similar to one another? Why or why not?

EXAMPLE B Sachit wants to buy an above-ground swimming pool with a diameter of 20 feet or more. He has found one pool that he likes, but he cannot find a salesperson to tell him its size or help him measure it. He stands in front of the pool and lays his tape measure along the floor. He measures 4 feet to the nearest point on the circular wall of the pool and 10 feet to the outermost edge that he can see. Might Sachit be interested in buying this pool?

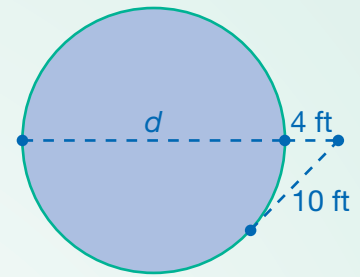

1

Identify the types of segments.

The line extending from where Sachit is standing to the farthest edge of the pool is a secant segment. Its length is the sum of his distance from the pool, 4 ft, and the diameter of the pool. His distance from the pool is the external segment of that secant line.

The outermost edge of the pool that Sachit can see is a point of tangency. So, the distance from where he is standing to that point is a tangent segment.

2

Identify a relationship that can be used to solve for d , the diameter of the pool.

The lengths of a tangent segment and the external segment of a secant are known. The unknown quantity, the diameter, is the internal segment of the secant.

These quantities are related because the product of one secant segment and its external segment equals the square of the tangent segment.

$$(d + 4)(4) = (10)^2$$

3

Solve for the diameter.

$$(d + 4)(4) = (10)^2$$

$$4d + 16 = 100$$

$$4d = 84$$

$$d = 21$$

► The pool has a diameter of 21 feet, so this is a pool that Sachit might consider buying.

CHECK

Extend a radius from the center of the pool to the point of tangency to form a right triangle. Use the Pythagorean Theorem to check that the answer is correct.

Practice

Give examples of the following in the given circles.

Name the following in Circle O:

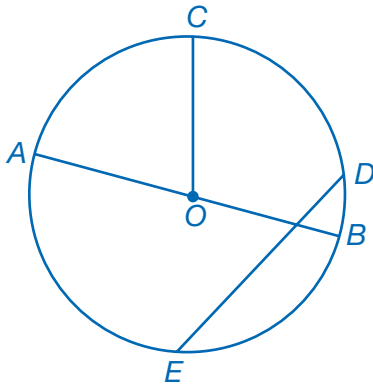

Name the following in Circle Z:

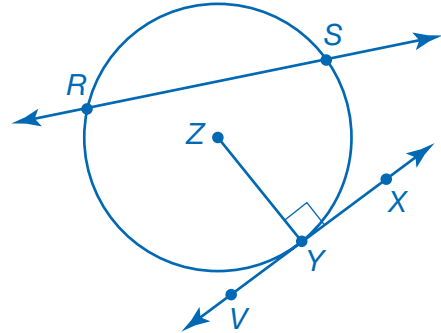

- | | |
|-----------------------|--------------------------|
| 1. The center: _____ | 5. A radius: _____ |
| 2. A diameter: _____ | 6. A chord: _____ |
| 3. Three radii: _____ | 7. A secant line: _____ |
| 4. Two chords: _____ | 8. A tangent line: _____ |

REMEMBER A secant line contains a chord.

Write *true* or *false* for each statement. If the statement is false, rewrite it so that it is true.

9. Every chord of a circle is also a diameter of the circle.

10. When two chords intersect inside a circle, the product of the divided segments of one chord equals the product of the divided segments of the other chord.

11. A diameter that intersects a chord bisects the chord.

12. A radius drawn to a point of tangency is perpendicular to the tangent line through that point.

13. A secant line intersects a circle in exactly one point.

Each circle shows intersecting chords. Find the length represented by x in each circle.

14.

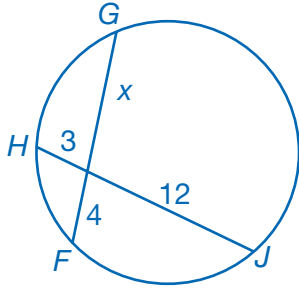

$x = \underline{\hspace{2cm}}$

15.

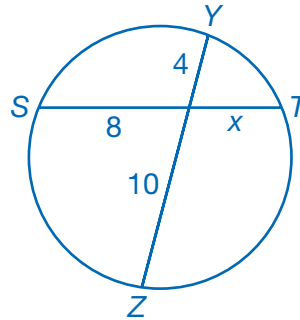

$x = \underline{\hspace{2cm}}$

16.

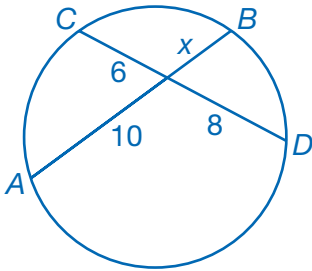

$x = \underline{\hspace{2cm}}$

17.

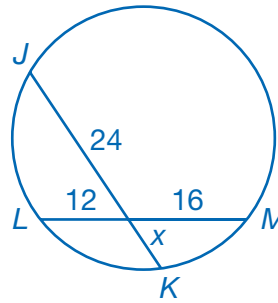

$x = \underline{\hspace{2cm}}$

18. Point O is the center of this circle.

$QR = 10$

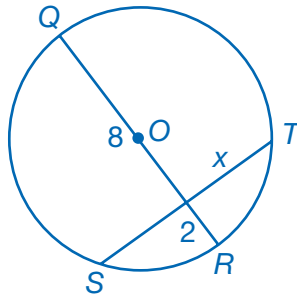

$x = \underline{\hspace{2cm}}$

19. Point O is the center of this circle.

$AB = 5x$

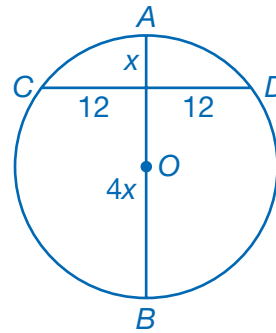

$x = \underline{\hspace{2cm}}$

Find the length represented by x in each diagram.

20.

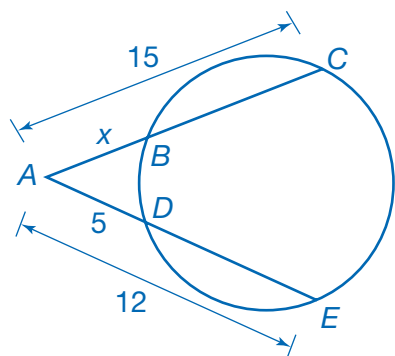

$x =$ _____

21.

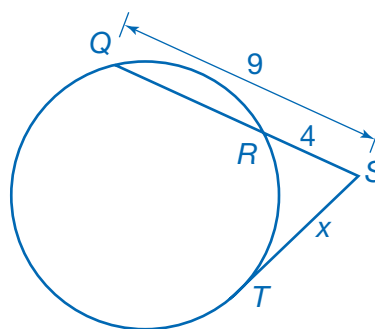

$x =$ _____

22.

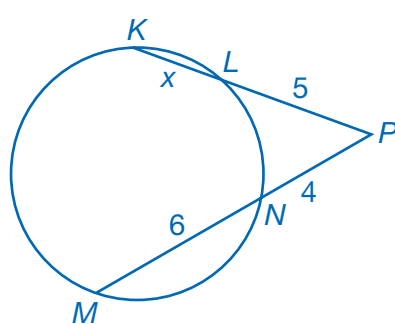

$x =$ _____

23.

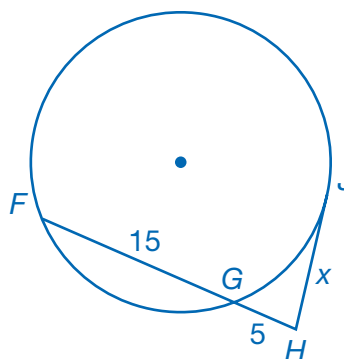

$x =$ _____

Find the length of the radius, r , for each circle.

24.

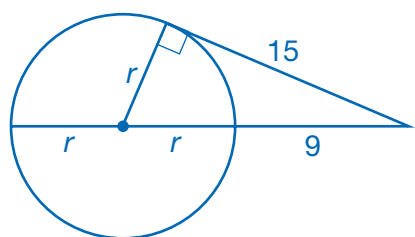

$r =$ _____

25.

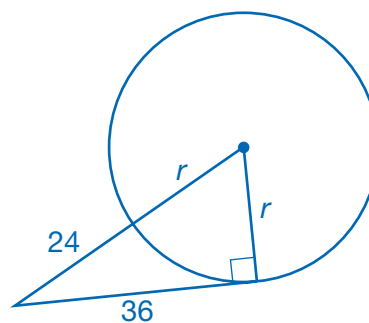

$r =$ _____

Choose the best answer.

26. A diameter of a circle is perpendicular to a chord whose length is 14 centimeters. If the length of the shorter segment of the diameter is 5 centimeters, what is the length of its longer segment?
- A. 2.8 cm C. 9.8 cm
B. 9 cm D. 19 cm
27. The diameter of a circle is 7 meters. If the diameter is extended 2 meters beyond the circle to point P , how long is a tangent segment from point P to the circle? Give your answer to the nearest tenth of a meter.
- A. 3.7 m C. 9.0 m
B. 4.2 m D. 18.0 m

Solve.

28. A scientist uses a satellite in orbit to estimate the diameter of Earth. When the satellite is directly overhead, she sends a signal to the satellite in order to measure its altitude. She records a distance above her of 1,000 miles. As the Earth turns, the satellite eventually moves to the horizon. At this time, the scientist sends another signal and calculates that the satellite is 3,000 miles from her. What is the approximate diameter of the Earth, based on these measures?

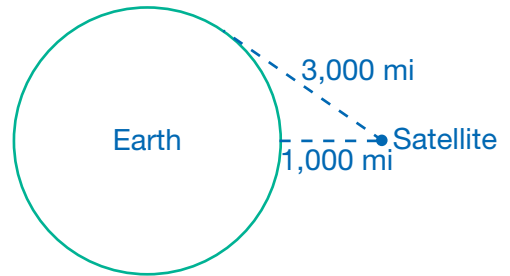

29. **EXPLAIN** Dilate the circle below twice. One dilation should produce an enlargement. The other should produce a reduction. Identify the scale factor you used for each. Are all three circles similar to one another? Explain why this is so.

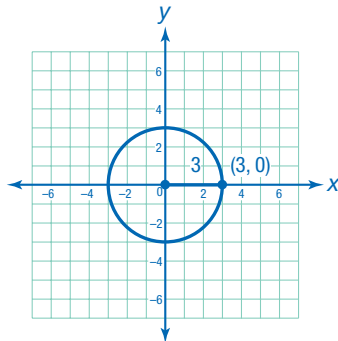

30. **PROVE** Marcus made this statement: "Two tangent segments drawn from the same point P outside of a circle must be congruent." Is he correct? Use Circle O , tangent segments PM and PN , and secant segment PK to justify your answer.

