



Venn Diagrams and Geometric Probability

UNDERSTAND The probability of an event, A , occurring is represented as $P(A)$. Probability is expressed as a number from 0 to 1 that shows how likely the event is to occur. It can be written as a fraction, a decimal, or a percent and is given by the following ratio:

$$P(A) = \frac{\text{number of favorable outcomes}}{\text{total number of possible outcomes}}$$

So, for example, if you toss a number cube, there are 6 possible outcomes: {1, 2, 3, 4, 5, 6}. Suppose you want to know the probability of tossing an even number. In that case, there are 3 favorable outcomes: {2, 4, 6}.

$$P(\text{even}) = \frac{3}{6} = \frac{1}{2} \text{ or } 0.5 \text{ or } 50\%$$

UNDERSTAND **Joint probability** is the probability that two events will occur at the same time or one right after the other. For example, suppose you have two bags, each containing four cards lettered A, C, E, and G. Suppose you want to determine the probability of selecting vowels (A or E) from both bags. Placing the possible outcomes in a Venn diagram allows you to analyze them. Circle F represents selecting a vowel from the first bag. Circle S represents selecting a vowel from the second bag.

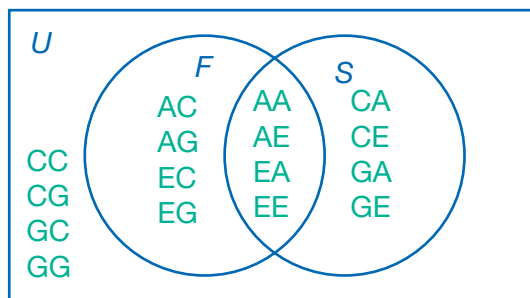

There are 16 possible outcomes. Of those, 8 involve selecting a vowel from the first bag, 8 involve selecting a vowel from the second bag, 4 involve selecting two vowels, and 4 involve selecting no vowels. Note that all outcomes are equally likely. The number of outcomes in a region divided by the total number of outcomes gives the probability for the event that the region represents.

There are 4 outcomes in the intersection of the sets, so the probability that you will select a vowel from both bags is $\frac{4}{16} = \frac{1}{4}$.

UNDERSTAND For problems involving **geometric probability**, instead of counting the number of outcomes in a region, you find the total length, area, or volume of a region. For example, consider a target with a radius of 24 inches and a bull's-eye of radius 2 inches. The probability of hitting the bull's-eye when the target is hit is equal to the ratio of the area of the bull's-eye to the area of the target.

$$P(\text{bull's-eye}) = \frac{\pi(2)^2}{\pi(24)^2} = \frac{4\pi}{576\pi} = \frac{1}{144} \approx 0.0069$$

The geometric probability of hitting the bull's-eye is about 0.69%.

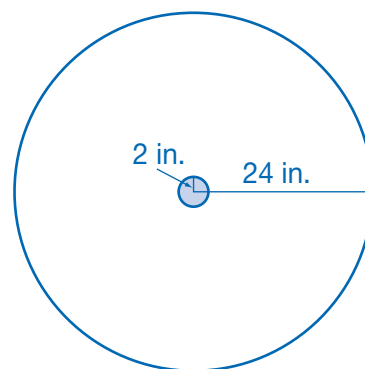

Connect

Lila is spinning a spinner with sectors numbered 1 to 8 and recording the results. Event A is spinning an odd number. Event B is spinning a number greater than 2. The Venn diagram shows the possible outcomes for this experiment.

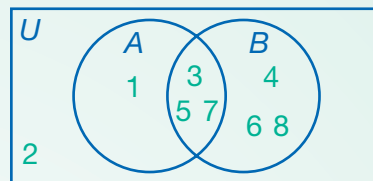

Create a second Venn diagram to show the probabilities of the following:

$$A - B, B - A, A \cap B, \text{ and } \overline{A \cup B}.$$

1

Find $P(A - B)$ and $P(B - A)$.

There are 8 possible outcomes:

1, 2, 3, 4, 5, 6, 7, and 8.

The region of circle A that does not overlap with circle B contains only one outcome: 1. So, $P(A - B) = \frac{1}{8} = 0.125$.

The region of circle B that does not overlap with circle A contains three outcomes: 4, 6, and 8. So, $P(B - A) = \frac{3}{8} = 0.375$.

2

Determine $P(A \cap B)$.

The region where circles A and B overlap shows their intersection.

There are three outcomes, 3, 5, and 7, in that region. So, $P(A \cap B) = \frac{3}{8} = 0.375$

3

Determine $P(\overline{A \cup B})$ and write the probabilities in a Venn diagram.

All of the outcomes inside circles A and B show the union of events A and B .

So, its complement is the one outcome, 2, that is outside the circles.

► $P(\overline{A \cup B}) = \frac{1}{8} = 0.125$

4

Draw the Venn diagram of probabilities.

Write the probabilities in the corresponding regions.

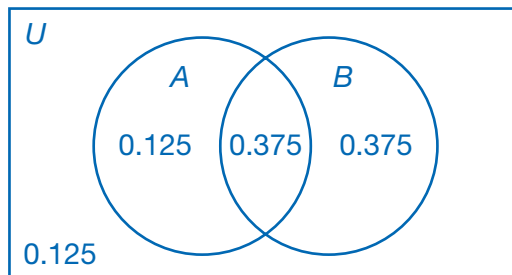

CHECK

Add together all four probabilities. What is the sum? Why?

Tree Diagrams and Two-Way Tables

UNDERSTAND Suppose you toss two fair coins—a nickel and a quarter—at the same time. Each coin can land on either heads (H) or tails (T). So for each individual coin toss, the probabilities are:

$$P(H) = \frac{1}{2} \qquad P(T) = \frac{1}{2}$$

However, the probability of both coins landing on heads, $P(HH)$, is not $\frac{1}{2}$. Drawing a **tree diagram** to represent all the possible outcomes can help you see this. The last column of the tree diagram below shows that there are 4 possible outcomes: {HH, HT, TH, TT}. All outcomes are equally likely, so the probability of each outcome is $\frac{1}{4}$. That means $P(HH) = \frac{1}{4}$.

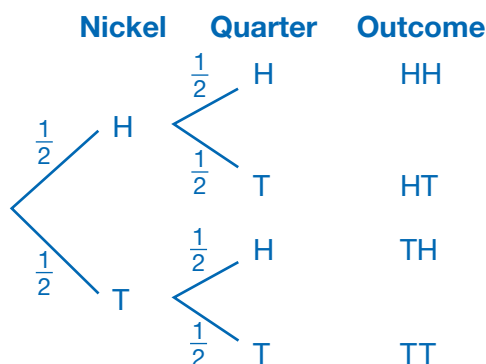

UNDERSTAND Probabilities can also help you understand data that are collected by surveying a representative **sample** of people drawn from a larger **population**. If you want to compare two categorical variables such as gender and reading habits, you can construct a **two-way frequency table** like the one below. The table shows **joint frequencies** and **marginal frequencies**.

	Reads for Pleasure	Reads Only for School	Total
Boys	20	30	50
Girls	30	20	50
Total	50	50	100

Joint frequencies are in the body of the table.

Marginal frequencies are in the “Total” row and “Total” column.

If you divide a particular frequency by one of the totals, you can determine its **relative frequency** by row, by column, or for the entire table. For example, $\frac{20}{50}$, or 40%, of all the boys surveyed said they like to read for pleasure, and $\frac{20}{100}$, or 20%, of all the people surveyed above were boys who said they like to read for pleasure. This means that if you select a boy from the population at random, there would be a 40% chance that he reads for pleasure, and if you select a person from the population at random, there would be a 20% chance that that person would be a boy who reads for pleasure.

Connect

The table shows the results of a survey of students in grades 9, 10, 11, and 12 that asked them if they preferred rock music or rap music.

What is the chance that a student chosen from the school at random is a 10th-grade student who prefers rap music to rock music?

	Rock	Rap
9th Grade	15	35
10th Grade	26	24
11th Grade	25	25
12th Grade	32	18

1

Extend the table.

The table above shows only joint frequencies. Add the numbers in the columns and rows to find the marginal frequencies.

	Rock	Rap	Total
9th Grade	15	35	50
10th Grade	26	24	50
11th Grade	25	25	50
12th Grade	32	18	50
Total	98	102	200

2

Find the cell (joint frequency) and total (marginal frequency) that you need.

Look at the cell in the table that lies in the 10th-grade row and the rap column. That cell contains the value 24.

The question asks for the probability of choosing a 10th grader who prefers rap from among all the students at the school. So, use the total for the entire table, 200.

3

Calculate the probability.

$$P(\text{10th grader who prefers rap}) = \frac{\text{number of 10th graders who prefer rap}}{\text{total number of students}} = \frac{24}{200} = 0.12$$

► If a student is selected from the school at random, there is a 12% chance that the student will be a 10th-grade student who prefers rap.

TRY

What is the chance that a student chosen from the school at random prefers rock music?

EXAMPLE A Miguel has a chest with three drawers. One drawer contains T-shirts, another contains shorts, and a third contains pairs of socks. Miguel will choose an outfit by reaching into each drawer and choosing one item without looking. The tree diagram shows the possible combinations of a T-shirt, shorts, and a pair of socks that he could select.

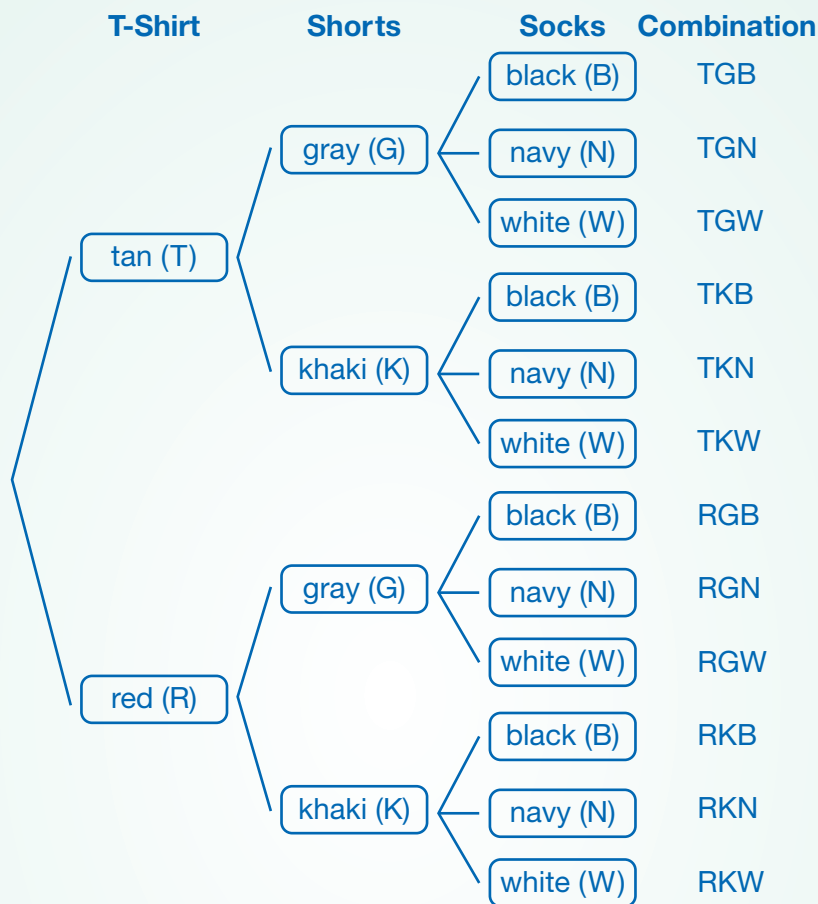

If each outfit has an equal probability of being chosen, what is the probability that Miguel will select a red T-shirt, khaki shorts, and white socks?

1

Identify the sample space.

The 12 different combinations of T-shirts, shorts, and socks make up the sample space. So, there are 12 possible outcomes.

2

Find the probability.

The outcome RKW shows selecting a red T-shirt, khaki shorts, and white socks. That outcome appears once in the sample space, so there is one favorable outcome.

$$P(RKW) = \frac{\text{favorable outcomes}}{\text{total possible outcomes}} = \frac{1}{12}$$

TRY

What is the probability that Miguel will select gray shorts as part of his outfit?



Problem Solving

READ

The spinner shown is for a carnival game. It has a radius of 3 feet and is divided into unequal sectors. The sector marked "Grand Prize" has a central angle of 36° . What is the probability of winning the grand prize on a given spin?

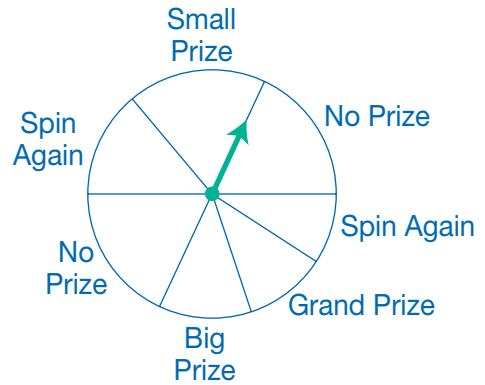

PLAN

To find geometric probability, find $P = \frac{\text{particular area}}{\text{total area}}$. The particular area is the area of the _____ . The total area is the area of the _____ .

SOLVE

First, find the total area.

$$A_{\text{total}} = \pi(\text{_____})^2 = \text{_____} \pi \text{ in.}^2$$

Next, find the particular area.

The central angle of the sector is _____ $^\circ$.

$$A_{\text{particular}} = \text{_____} \pi \cdot \frac{\text{_____}}{360^\circ} = \text{_____} \text{ in.}^2$$

Finally, find the probability.

$$P(\text{Grand Prize}) = \frac{\text{_____}}{\text{_____}} = \text{_____}$$

Expressed as a percent, the probability of winning the grand prize is about _____ %.

CHECK

In actuality, the probability does not depend on the radius or area of the circle.

$$P(\text{Grand Prize}) = \frac{\text{_____}}{360^\circ} \cdot \frac{\pi r^2}{\pi r^2} = \frac{\text{_____}}{360^\circ} = \text{_____}$$

Is this value equal to the probability found above? _____

➔ The probability that a given spin will win the grand prize is _____.

Practice

Identify the probability for each simple event.

- tossing a number cube with faces numbered 1 to 6, and getting 3.
- Drawing a spade from a standard 52-card deck

HINT  A deck of cards has 4 suits.

For each Venn diagram and situation, determine $P(A - B)$, $P(B - A)$, $P(A \cap B)$ and $P(\overline{A \cup B})$. In the blank Venn diagram, write those probabilities in the appropriate sections.

- Two puppies were born. Event A represents a female puppy being born first. Event B represents a female puppy being born second.

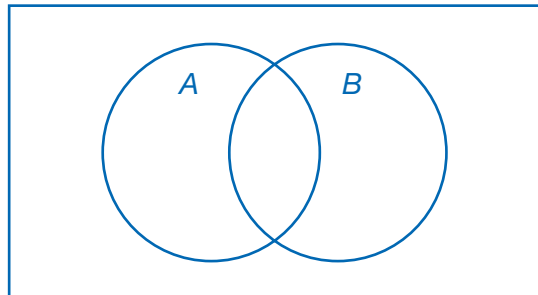
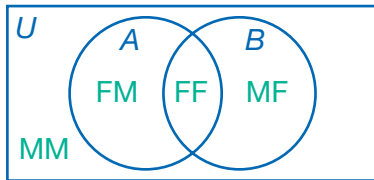

- Two spinners each have sections numbered 1–3. Event A represents getting an odd number on the first spinner. Event B represents getting an odd number on the second spinner.

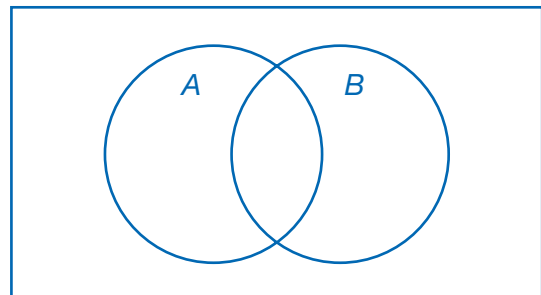
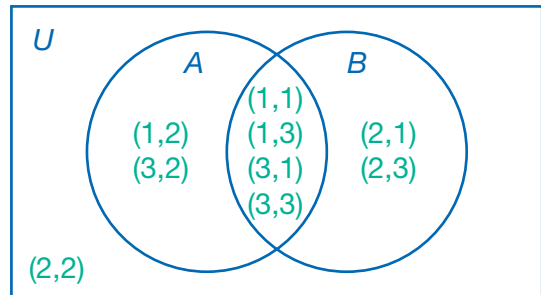

HINT  (1, 2) shows spinning a 1 on the first spinner and a 2 on the second spinner.

Use the information below for questions 5 and 6.

A bag contains six marbles. Four of the marbles are striped: one red/black, one red/green, one blue/gray, and one blue/white. Two of the marbles are solid colors: one solid white and one solid green. Curtis will reach into the bag and pick a marble without looking. Event R is picking a marble that is at least partially red. Event B is picking a marble that is at least partially blue.

5. Create a Venn diagram to show all the possible outcomes of one pick.



6. Determine each probability

$$P(R) = \underline{\hspace{2cm}}$$

$$P(B) = \underline{\hspace{2cm}}$$

$$P(R \cap B) = \underline{\hspace{2cm}}$$

$$P(\overline{R \cup B}) = \underline{\hspace{2cm}}$$

The tree diagram represents tossing a fair coin 3 times. Use the tree diagram for questions 7–9.

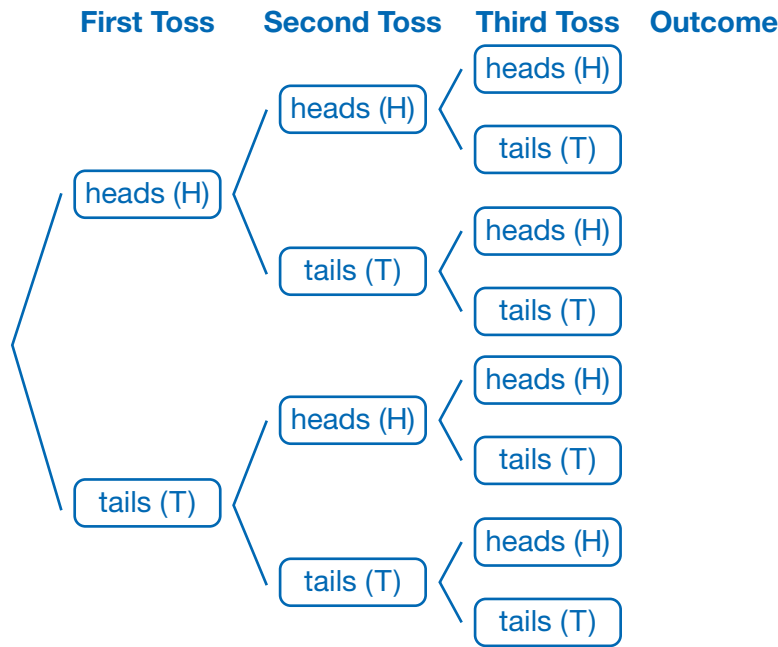

7. List all the possible outcomes on the tree diagram.

8. Each outcome is equally likely. What is the probability of tossing 3 tails?

9. What is the probability of tossing heads on at least 2 tosses?

Use the table below for questions 10–12.

The table shows the results of a survey of people in different age groups. The survey asked each person if he or she was for or against a proposal to build a new high school in town.

Age	For	Against	No Opinion	
18 to 35	20	34	6	
35 to 65	25	32	3	
65 and over	18	27	15	

10. Extend the table to show the marginal frequencies.
11. What is the chance that a person over the age of 65 has no opinion about the proposal? _____
12. What is the chance that an adult selected at random is for the proposal? _____

Calculate the probabilities.

13. The target shown has a radius of 1 meter. The bull’s-eye has a radius of 5 centimeters. The point value of each section of the target is written in the section. Find the following geometric probabilities, and express them as a percent. (Hint: Your answers should add up to 100%)
14. A cake in the shape of a cylinder has a radius of 6 inches and a height of 4 inches. The baker put a plastic figure in the cake, and whoever finds the figure wins a prize. Annie gets a slice of cake with a central angle of 20° . The area of a sector of a cylinder is equal to the area of the sector’s base times its height. Find the geometric probability that Annie will get the prize. Express your answer as a fraction in lowest terms.

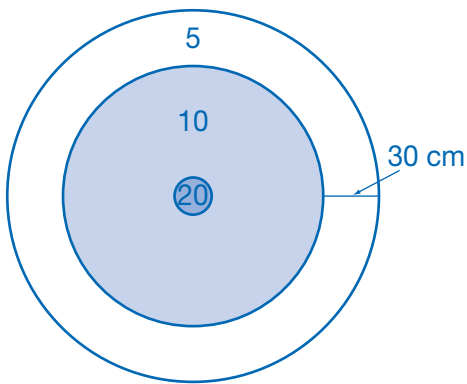

$P(5 \text{ points}) =$ _____

$P(10 \text{ points}) =$ _____

$P(20 \text{ points}) =$ _____

Use this information for questions 15 and 16.

Fifty students were asked which television genre they like best. Five boys said drama, eight boys said sitcom, and twelve boys said reality. Eight girls said drama, ten said sitcom, and seven said reality.

15. Use the grid below to create a two-way frequency table for these data.

				Total
Boys				
Girls				
Total				

16. **EXPLAIN** What is the probability that a student who likes sitcoms best is a girl? Explain how determined your answer.

Solve.

17. **MODEL** A pirate has forgotten exactly where he buried his gold coin, but knows that it is somewhere within a 20-foot-by-30-foot rectangular area on the beach. He only has time to dig a 5-foot-by-5-foot square hole before high tide comes in. Sketch a model of the problem and determine the geometric probability that the pirate will find the gold coin.
